

Data Sheet



Article number: 2308051531

Description: E+G Index plunger
PMT.100-8-M16x1.5-AK

Measures

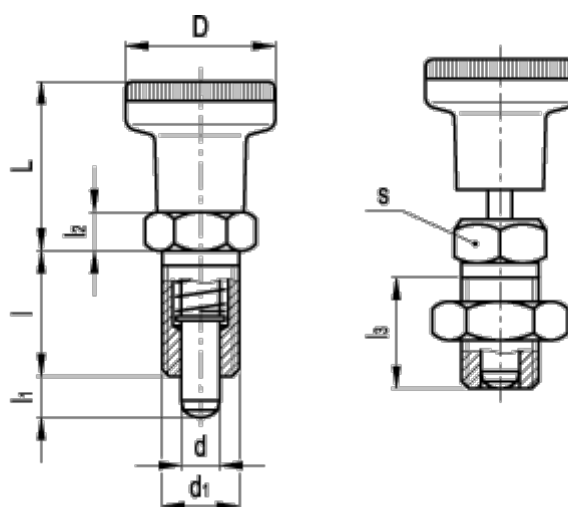

Code = PMT.100-8-M16x1,5-AK

D = 31

d = 8

d1 = M16x1.5

l = 26

L = 35

l1 = 8

l2 = 8

l3 = 23

Max. axial load (N) = 30

s = 19